

The 20th Annual Intelligent Ground Vehicle Competition
June 8 - June 11, 2012

Bearcat Cub Micro University of Cincinnati



CERTIFICATION:

I certify that the engineering design in the vehicle Bearcat Cub (original and changes) by the current student team identified in this Design Report has been significant and equivalent to what might be awarded credit in a senior design course.

Professor Dan Humpert, Advisor

Contents

Introduction.....	3
Design Innovations	3
Design Process and Team Organization	3
1. Hardware.....	5
Frame	5
Design of the Bearcat Cub Micro	5
Drivetrain	6
Power System.....	7
Emergency Stop	7
Motion Controller	8
2. Electrical and Electronic Systems.....	9
Laptop	11
Laser Measurement System	11
Global Positioning System (GPS).....	11
Cameras.....	11
Compass.....	11
3. Software	12
Mapping	12
Lane Detection Algorithm	12
Path Planning	13
Vector field general theory	13
Modified Vector field Concept	14
Navigation.....	15
Obstacle Avoidance	15
Conclusions.....	16
References.....	16
Appendix A: Bill of Materials	16

Introduction

This year marks the 20th consecutive year that the University of Cincinnati Robotics Team has participated in the IGVC. This year's robot is an improved version of our 2011 platform. The electrical system has undergone major upgrades to improve reliability as well as the range of the wireless e-stop, and the software has been modified to improve the positional accuracy of the robot and adapt to this year's Auto-Nav challenge. This report describes the various aspects of Cub Micro's design, design tradeoff considerations and improvements over the past IGVC entries by the UC Robotics team.

Design Innovations

The major design innovations this year compared to last year are:

- New wireless E-stop
- New E-stop circuit
- New power inverter
- New wiring chassis
- Integration of wheel encoders in position estimation
- Refactored C++ code
- Fewer software bugs

Design Process and Team Organization

Since our team had two existing IGVC robots (the Cub Micro and the Cub VI), our design process lay in choosing which robot to focus our energy on and what improvements to make. The first quarter, we worked on both robots to improve them as much as we could. The second quarter, we focused attention on the Cub Micro as we felt it was the more tried and tested robot. The Cub V is the robot that we brought to the IGVC this year and is the subject of this report.

The IGVC team consists of two senior mechanical engineers plus underclassmen new to robotics this year. The team met in its entirety on a weekly basis, and member contributed time during the week as well. A huge focus in our team was for the senior team members to pass on knowledge about the robot's design, operation, and code to the new younger members, so there would be

students capable of continuing our team's annual participation in the IGVC next year. Our advisor was Professor Dan Humpert, who met with us on a weekly basis.

Table 1. Team Organization

<i>Role</i>	<i>Name</i>	<i>Major</i>	<i>Year</i>
Captain / Senior Design	William Hilton	Mechanical Engineering	2012
Senior Design	Nicholas Vuotto	Mechanical Engineering	2012
Hardware	Amanda LaCombe	Mechanical Engineering	2014
Software	Curtis Schumacher	Computer Science	2015
Software	Jon Neal	Electrical Engineering	2015
Software	Pete Kayuha	Computer Science	2016
Hardware	Rachelle Palmer	Mechanical Engineering	2016

This report is divided into sections, each explaining the different modules of the robot and can be categorized as following.

1. **Hardware Design:** This section describes the basic platform along with the hardware components which includes the framework, power system, the emergency stop and the motion control system.
2. **Electrical and Electronics system:** The section lists out in brief the computer system and the various sensors with schematics of its integration.
3. **Software design:** Describes in detail the algorithm used for mapping, lane detection, the vector field approach and path planning.

1. Hardware

Frame

The load bearing chassis of the Cub Micro is made of 80/20 aluminum extrusion because it is light, strong, and easy to assemble. The key advantage of using this modular type frame comes in the ease of reshaping to adapt to new components or replacement components as they are brought into the design.

The aft shelving support uses aluminum window shade track which weighs less than 1/6th the equivalent length of 80/20. Despite this reduction in weight, the shelving is still able to support at least 135lbs of distributed load.

Design of the Bearcat Cub Micro

Over its history, the Bearcat Cub has undergone incremental improvements in design from the first generation golf cart, the second and third generation cubes, to the fourth generation robot. However the fifth generation, the Cub Micro, is significant for its smaller size. The sixth generation Bearcat Cub, which is not ready for this year's IGVC, is even more compact.

The frame of the Bearcat Cub IV was stripped completely and cut to size around our battery dimensions. Planning for this involved using a SolidWorks® CAD model that proved the feasibility of overlapping our 2hp brushless servo motors and using every bit of available space. During construction, numerous additional improvements were made particularly through tight wiring and unconventional placement of power electronics and motion control boards.

Table 2. Cub Micro design comparison

Bearcat Cub IV		Bearcat Cub Micro	
Pros	Cons	Pros	Cons
<ul style="list-style-type: none"> -Ample space -Easy to access -Instant energy replenishment 	<ul style="list-style-type: none"> -Easily broken caster wheels -Weighs 300 lbs -Too large -Disorganized -Difficult to transport -Gasoline fueled -Vibrations, loud 	<ul style="list-style-type: none"> -Half the volume -Weighs 180lbs -Easy to remove sensor tower -Well utilized space -Organized, more presentable -Sturdier design -15 hr mean run time before recharge -Quiet operation -Top slides to convert into a desk 	<ul style="list-style-type: none"> -Hard to access -Limited run time -11 hr recharge

Drivetrain

The Micro has two types of wheels – two main drive wheels and two rear castor wheels. The 19 inch drive wheels are enhanced traction wheels designed by Michelin for Segways. They consist of a forged steel wheel hub with a glass reinforced thermoplastic rim. The tires are made of a silica compound, which provides good traction even on wet surfaces.

The 10” rear castor wheel provides the stability needed for the Micro to perform zero turning radius turns. The robot is designed to run at a maximum speed of 5 miles/hour. Although the maximum speed for the IGVC has since been increased to 10 miles/hour, the drivetrain cannot be made to run much faster without overloading the power system. A Pacific Scientific PMA43R-0011200, 2H.P brushless servo motor has been installed on each drive wheel with a gear box of ratio 25:1. The gearbox and motors have been selected based on the design calculations taking frictional coefficient of 0.125 and 70% gearbox efficiency. This design incorporates the gearbox inside the hub of the wheel resulting in a compact and robust design.

Because the frame of the Cub Micro has been so successful the past two years, no significant changes were made to the frame this year. Instead, focus was directed towards the areas that needed more attention, electrical and software.

Power System

The robot is powered by two 12v deep cycle marine lead acid batteries connected in parallel for total energy storage of 2064 watt-hours. Power from the battery is sent to a 1500W 120V inverter which powers all electronics including the motor amplifiers. The inverter is new this year and replaces the 800W inverter that could never deliver enough power to run the Cub at max speed, or up steep hills. The new inverter solves this problem by doubling the available current to the motors. Using batteries allows for silent, vibration and smoke free operation compared to a compact generator. The downside is that the batteries need to be regularly maintained and refilled with distilled water or they start to go bad.

Emergency Stop

The robot stops using electronic dynamic braking that dissipates heat through a resistive load shunt. A manual E-stop button is located on the rear of the vehicle more than 2 feet above the ground which activates the brakes. A wireless remote control can also trigger the brakes from a distance of >100 feet. A new Remote Engine Shut-off for 12V Vehicles from 3Built LLC replaces the old Futaba wireless system in order to achieve this range.

One of the major design changes this year was replacing the E-stop circuit. The old E-stop circuit was based on a hacked GFCI, and had many loose wires. The new circuit is based on an A/C relay and is much simpler. Figure 4 shows a comparison between the new and old e-stop.

Table 3. E-stop Comparison

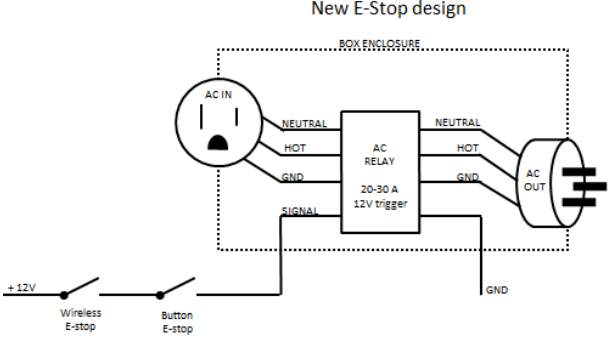
Old E-Stop		New E-Stop	
			
Pros	Cons	Pros	Cons
-GFCI based shut off, industrial grade.	-Complex: 3 different cables/ports controlling operation. -Multiple exposed wires. -Poorly documented / unmaintainable. -Added a step to reset.	-Simple, easy to understand design. -Supports easy chaining of additional e-stop triggers. -Reliable.	-Lacks GFCI protection.

Motion Controller

The Galil DMC 2130 motion control board is used for the Micro and is controlled through commands sent via a serial hub connected to the laptop. Copley amplifiers deliver power to the motors after amplifying the signals they receive from the motion controller. Steering is achieved by applying differential speeds at the right and left wheels. The Galil motion controller was chosen because it supports both serial and Ethernet interfaces, has PID and Bode plot tuning software, and is enclosed in a durable package. (As proven by its many years of trusty service.) The controller can accommodate up to 4 axis and can control stepper or servo motors on any combination of axes. The Cub Micro has the ability to turn about its drive axis effectively performing a Zero Turning Radius (ZTR) pirouette. The block diagram of the system is shown in Figure 1.

Figure 1. Motion control system

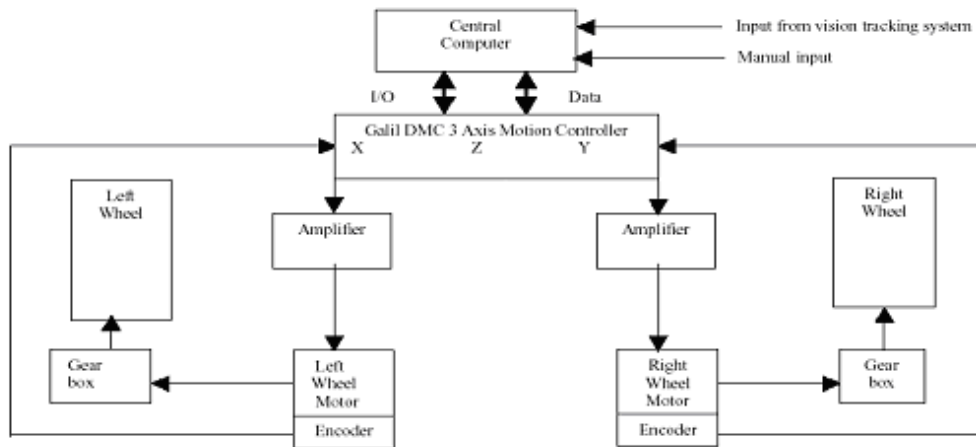

2. Electrical and Electronic Systems

The electrical systems of the Bearcat Micro consists of a motion controller, 2 amplifiers, 2 DC brushless motors, 2 digital cameras, a Bumblebee stereo-vision camera, a laser scanner, a GPS unit, and an emergency stop. Power is fed from the inverter to two sets of traditional power strips. This allows the Bearcat Micro to be outfitted with any set of sensors very easily since there is no need for the end user to customize any power supplies. The system acts like a hardware equivalent of software plug and play. Figure 3 on the following page shows a schematic of the general electronics layout.

Figure 2. Docking Station Schematic

The locations of the USB cables matter

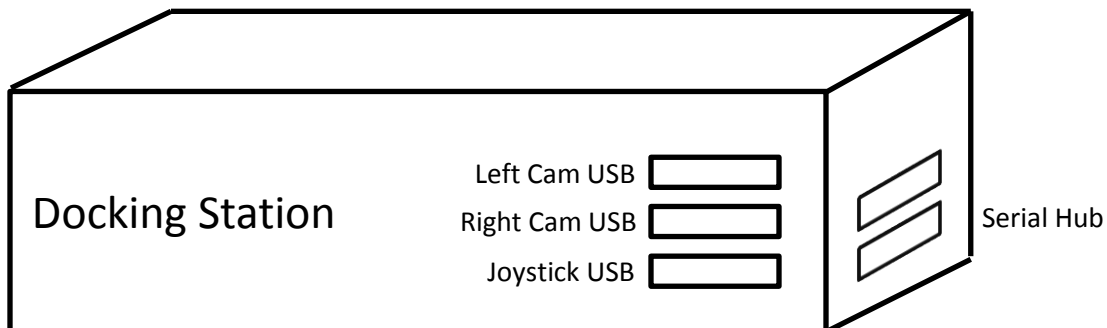
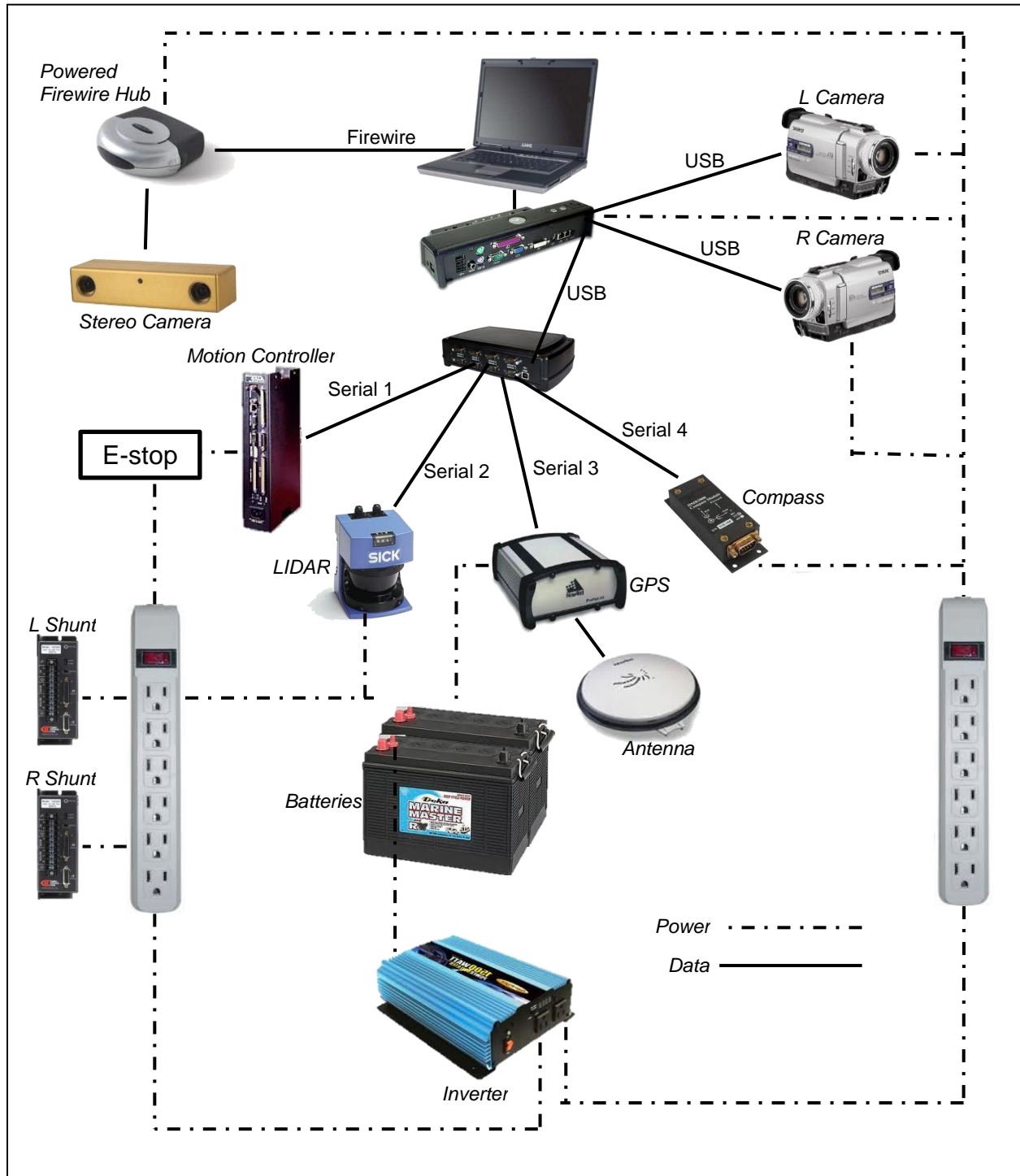

Figure 3. General Wiring Schematic



Laptop

A Dell Latitude D830 laptop is the central processing unit of the Bearcat Micro. It has a 2.6 dual core Intel processor with 3.5GB RAM. It processes data from the laser scanner, GPS, motion control system and image processing system. The controlling software is written in C++ and uses the Open Computer Vision library to process image data and display it on the screen. A series of initialization files hold all the calibration values and initial values for the system parameters.

Laser Measurement System

The Sick LMS 200 scans a 2-dimensional plane of 180 degrees and returns obstacle distance measurements for up to 8.191 meters with an infrared laser beam (835 nm wavelength) based on its time of flight. The resolution of scan is 1 degree. It is communicating with the computer using a RS 232 ports with a data transfer rate of 38,400 bauds.



Global Positioning System (GPS)

A NovAtel's ProPak-V3 is a durable, high-performance receiver with advanced capabilities using a USB communication. The accuracy achieved with this unit is 0.6m using SBAS channel.



Cameras

Two Sony DCR-TRV118 video cameras provide the images that are used by the line detection system. Wide angle lenses and built in image stabilization improve image quality.



Compass

Honeywell HMR3200 digital compass is a 2 axis precision compass. The compass is oriented horizontally on the rigid body of the Micro. It provides 1 degree accuracy and operates at 19200 baud rate providing fast and accurate heading information to the robot for accurate path planning.



3. Software

Mapping

The Bearcat Micro keeps track of a map of its surroundings as it moves through the environment. This map consists of all the detected obstacles latitude and longitude positions. Each sensor, running on separate threads, will inform the other parts of the program when an obstacle is detected and the distance the obstacle is from the robot. The map will then use the robots location and heading to calculate the latitude and longitude of each detected point via the following Equations 1 and 2.

$$x = x_o + (r \times \cos(\theta + \varphi) / R) \quad (1)$$

$$y = y_o + (r \times \sin(\theta + \varphi) / (R \times \cos(x_o))) \quad (2)$$

Where x_o is the robot's latitude, y_o is the robot's longitude, θ is detected angle of the object from the robot, φ is the robot's heading, and R is the mean Earth radius in meters. The resulting x and y is the obstacle's latitude and longitude respectfully.

Lane Detection Algorithm

Our lane detection algorithm captures two images from the cameras located on either side of the robot. The colors of each image are filter out so as to enhance the white lane markers' contrast and remove everything else from the image. The image is then converted to a binary image and simple noise removal is done. The results are seen in the figures below. Left is the original image; right is the image once transformed into binary image.

Figure 4. Lane Detection

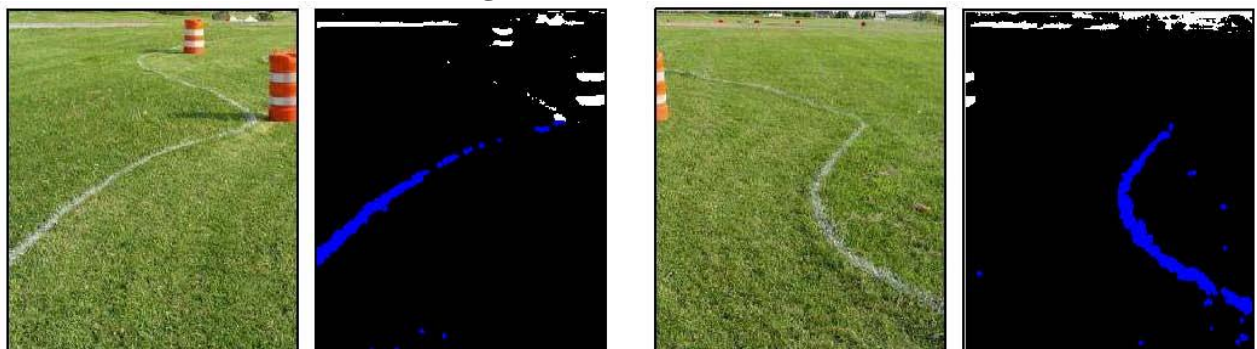

In each image, all the white points in the image are taken and fit using a Hough transform from the OpenCV library. A weight is determined using the number of white points in each image. This weight is used to create a weighted mean slope from the slopes obtained from both images. The position of the robot with reference to both lines is calculated by finding the midpoint of the intersection of both the left and right lines and the yaxis. This gives us the proper information to send to the mapping algorithm so that the lines can be modeled as obstacles. The resulting lines are shown in the figure below.

Figure 5. Hough Fit Lines for Each Camera

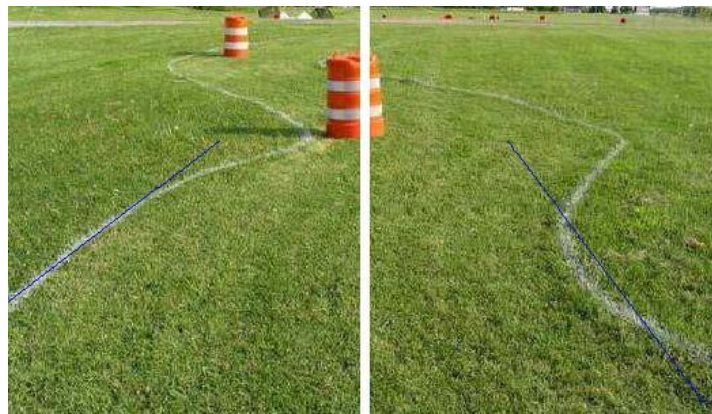

Path Planning

Our approach builds on general vector field theory. In this theory obstacles apply force on the robot that pushes the robot away from the obstacles. The sum of all the forces will dictate the direction the robot chooses. The force applied to the robot from a particular obstacle is proportional to the distance the robot is from the obstacle⁵.

Vector field general theory

In the vector field concept (VFC)^{1 3 4} the robot is considered to be in a force field where all the obstacles push the robot away and the target pulls the robot to it.

Figure 6. Robot with two obstacles and a target location

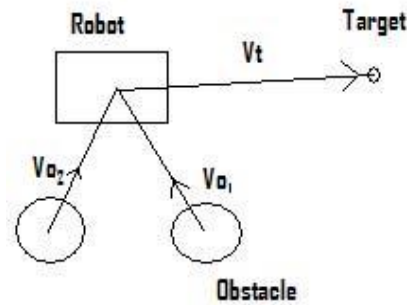

The resultant force acting on the robot is the sum of the repulsive force from the obstacles and the attractive force from the waypoint target as shown in Equation (3).

$$\vec{V}_p = \vec{V}_r + \frac{1}{n} \sum_{i=1}^n \vec{V}_{o_i} \quad (3)$$

where n is the number of obstacles in range and V_{oi} is the force exerted by them on the robot. V_T is the pulling force exerted by the target on the robot. Note that the magnitude of the force exerted by the obstacle decreases with distance from the robot. The magnitude of the waypoint or target vector remains constant irrespective of the magnitude of force exerted by obstacles.

Modified Vector field Concept

The VFC uses just one vector to represent the obstacle. It is possible that obstacle might have a part sticking out of the main body. This may become a potential hazard for the robot. If multiple vectors were considered originating from the visible surface of the obstacle the robot would know about the protruding part.

Figure 7. Multiple obstacle vectors covering the entire visible area

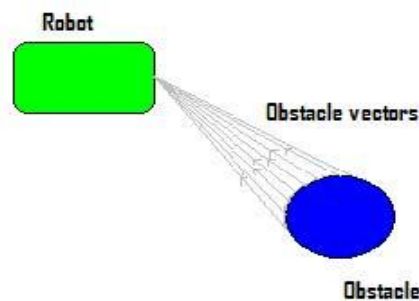

This enables the robot to pass very close to the obstacle and through narrow passage ways. The magnitude of the obstacle vectors is determined by Gaussian distribution shown in Equation (4)

$$|\vec{V}_0| = ke^{-\frac{(x-\mu)^2}{2\sigma^2}} \quad (4)$$

The resultant of all obstacle vectors forms the final obstacle vector.

Navigation

Navigation is accomplished by using a Kalman filter to integrate data from a digital compass, the encoders in the servo motors, and one or more GPS devices. This data determines a heading, subject to obstacle avoidance. After the position estimate is within a critical radius of the target waypoint, the robot will spiral out to a variable radius, making the system more robust to GPS errors. The heading computed between the estimated and target positions is then modified by the obstacle avoidance algorithm.

Figure 8. Navigation simulation showing spirals around waypoints

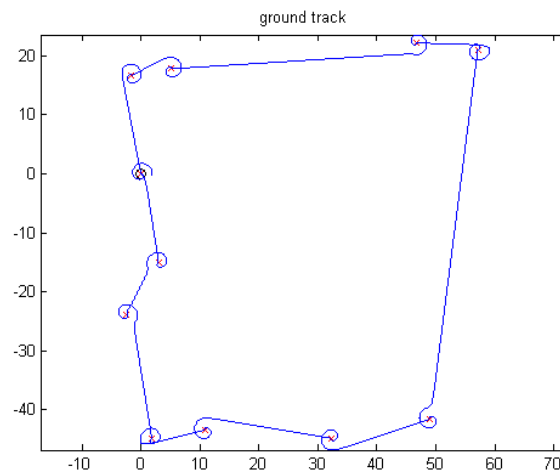

Obstacle Avoidance

The obstacle avoidance is a force vector field variant. It takes its primary inputs from the laser scanner, but is augmented with information from the cameras and stereovision system. This means that lines can be considered as obstacles to be avoided, and obstacles that are transparent to the laser (either too high, like tables or mesh-like, like fences or bushes).

Conclusions

We have addressed the major electrical problems that historically have plagued UC at the IGVC competition. Thus, we feel more confident that this year our robot will travel further along the course than last year's short run. Ultimately however, we will judge our success based upon how well the team survives the knowledge continuity gap once the graduating seniors leave.

References

- [1] J.C. Wolf, P. Robinson and J.M. Davies "Vector Field Path Planning and Control of an Autonomous Robot in a Dynamic Environment," FIRA Robot World Congress. 2004.
- [2] A. Guttman, "RTrees: A Dynamic Index Structure for Spatial Searching", Proc. 1984 ACM SIGMOD International Conference on Management of Data
- [3] I. Ulrich, and J. Borenstein, "VFH+: Reliable Obstacle Avoidance for Fast Mobile Robots," IEEE Int. Conf. on Robotics and Automation, May 1998, pp. 15721577.
- [4] I. Ulrich, and J. Borenstein, "VFH*: Local Obstacle Avoidance with LookAhead Verification." IEEE Int. Conf. on Robotics and Automation, April 2000, pp. 25052511.
- [5] R. Siegward, I.R. Nourbakhsh "Introduction to Autonomous Mobile Robots," MIT Press, Cambridge, Massachusetts, London, England, 2004, pp. 267272.

Appendix A: Bill of Materials

Part	Manufacturer	Model No	Quantity	Unit Price	Total
Frame	80/20 Inc.	Custom design	1	950	950
Batteries	Rocket	DC31DT	2	85	190
Motors	Pacific scientific	PMA43R0011200	2	970	1,940
Amplifiers	Copley Controls Corp.	Xenus Servo Drives XSL23036	2	540	1,080
Drive Wheels	Segway	Enhanced Traction	2	188	376
Gearboxes	Segway	HT design, 25:1 gear ratio	2	488	976
Laptop	Dell	D830	1	1,181	1,181
Cameras	Sony	PVDV51	2	290	540
Wireless Estop	3built	RES12VU	1	70	70
Motion controller	Galil Inc.	DMC2130 Ethernet	1	2,800	2,800
Inverter	PowerBright	1500 W	1	125	125
GPS	Novatel	ProPakV3HP	1	3,252	3,252
Miscellaneous				300	300
Total					\$13,780